

56 Sparta Avenue • Newton, New Jersey 07860
 (973) 300-3000 Sales • (973) 300-3600 Fax
 www.thorlabs.com



OCS1300SS - February 11, 2015

Item # OCS1300SS was discontinued on February 11, 2015. For informational purposes, this is a copy of the website content at that time and is valid only for the stated product.

SWEPT SOURCE OCT SYSTEMS

The OCS1300SS Swept Source Optical Coherence Tomography Imaging System

Cross-Sectional and Volumetric Optical Imaging



[Hide Overview](#)

OVERVIEW

Thorlabs OCS1300SS is Ideal for Applications Requiring Nondestructive, High-Resolution Imaging up to 3 mm in Depth.

Features

- 2D Cross-Sectional Imaging at 16,000 Lines per Second
- 3D Volume Imaging in less than 20 Seconds
- 25 μm (Lateral) x 12 μm (Depth) Resolution
- 10 mm x 10 mm x 3.0 mm Field of View
- Doppler Flow Imaging Included
- Includes Handheld Probe with Integrated Video Camera (See Product Details for a Description of all Items Included with each System)
- Easy Data Acquisition and Scan Control (2D and 3D) Using Included Software (See Software tab for more Details)

Thorlabs' Swept Source Optical Coherence Tomography System is ideal for imaging highly scattering samples such as small animals and biological tissue. The 1325 nm central wavelength and 6 mm coherence length of the swept laser source enables deep image penetration, up to 3 mm. The OCS1300SS includes a hand-held probe, probe mount, and computer with user software. Details are provided in the Product Details tab.

Optical Coherence Tomography (OCT) is a noninvasive optical imaging modality that provides real-time, 1D depth, 2D cross-sectional, and 3D volumetric images with micron-level resolution and millimeters of imaging depth. OCT images provide structural information of a sample, based on light backscattered from different layers of material within that sample. OCT imaging is considered to be the optical analog to ultrasound. OCT, however, achieves higher resolution through the use of near infrared wavelengths, at the cost of decreased penetration depth. In addition to high resolution, the non-contact, noninvasive advantage of OCT makes it well suited for imaging samples such as biological tissue, small animals, and industrial materials.

Compared to Spectral Domain OCT technology, Swept Source Optical Coherence Tomography does not suffer from inherent sensitivity degradation at longer imaging depths. Therefore, these systems are the preferred choice where long imaging depths are desired.

Thorlabs also offers extensions/variations to the OCS1300SS for imaging through an upright microscope (see our OCS1300SS Microscope) and for polarization diversity (birefringence) imaging (see our PSOCT Module).

OCS1300SS System Specifications*

Center Wavelength	1325 nm
Imaging Speed (A-Scan Line Rate)	16 kHz
Depth Resolution (Air)**	12 μm
Lateral Resolution (Includes LSM03 Scan Lens)	25 μm
Maximum Scan Dimensions	10mm x 10 mm x 3 mm
Maximum Pixels Per A-Scan	512

*See Specs Tab for more details.

**Depth resolution is dependent on the optical properties of the sample being imaged.



OEM and Custom Requests

Thorlabs offers OEM products for easy integration into your imaging system. With ISO9001 certified production facilities and experienced OEM design engineers, we welcome OEM requests.

Applications

Click on images below for details:

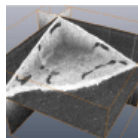

Biomedical

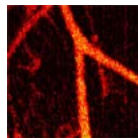

Vascular Imaging

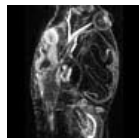

Biology

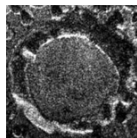

Industrial

Click here for a full list of peer-reviewed publications using Thorlabs OCT imaging products.

[Contact Us](#)

[Application Articles](#)

We also recognize that our customers have unique application requirements. For this reason, we stand ready to discuss how our OCT systems can be adapted to meet your needs. We encourage you to send us samples for product testing so our engineers can customize one of our OCT systems to suit your individual applications. Please use the "Contact Us" button on the upper right-hand side of the page for more information.

[Hide Specs](#)

S P E C S

System Specifications

Optical	
Center Wavelength	1325 nm
Spectral Bandwidth (FWHM)	>100 nm
Axial Scan Rate	16 kHz
Coherence Length	6.0 mm
Average Output Power	10 mW
Sensitivity	100 dB

Data Acquisition	
Analog/Digital Conversion Rate	100 MS/s
Analog/Digital Resolution	14 Bit
Analog/Digital Channels	2
Analog Output Rate	1 MS/s
Analog Output Resolution	16 Bit
Analog Output Channels	4

Computer (HP Z220 Workstation)	
CPU	Quad Core 3.2 GHz
Memory	4 GB SDRAM
Operating System	Windows 7, 32 Bit
Hard Drive	500 GB SATA 6.0 Gb/s
Optical Drive	16X DVD+/-RW
Graphics Card	Intel HD P4000
Monitor	HP LV1911 18.5"

Imaging Specifications

2D Cross-Sectional OCT Imaging Capability	
Imaging Speed (512 Lines per Frame)	25 fps
Maximum Imaging Size	4,000 x 512 Pixels
Maximum Imaging Width	10 mm
Maximum Imaging Depth	3.0 mm
Transverse Resolution	25 μ m
Axial Resolution	12/9 μ m (air/water)

3D Volumetric Imaging Capability	
Maximum Volume Size (L x W x D)	10 x 10 x 3 mm
Maximum Sampling Resolution (L x W x D)	1024 x 1024 x 512 Pixels
Imaging Time	Approx. 30 sec

Video Imaging Capability	
CMOS Sensor	5.78 x 4.19 mm
Maximum Resolution	510 x 492 Pixels
Imaging Speed	20 fps

[Hide Product Details](#)

PRODUCT DETAILS

Click on the OCS1300SS OCT Imaging System Components, shown below, for further details. Please note that the included computer system has been updated and does not match the one shown below. The specifications listed beneath the image provide information on the current included computer system.



OCS1300SS Processor

The OCS1300SS includes an HP Z220* workstation including an 18.5" monitor. This processing system is set up with all the necessary data acquisition hardware, drive electronics, and software to begin imaging upon arrival.

Computer Specifications*

- Quad Core 3.2 GHz Processor
- Windows 7, 32 Bit
- Intel HD P4000 Graphics Card
- 500 GB Hard Drive

Data Acquisition Specifications

- A/D Conversion Rate: 100 MS/s
- A/D Resolution: 14-bit

*Computer type and specifications subject to change

[Click Here to return to the top of the page.](#)

OCS1300SS Engine and Imaging Module

The OCS1300SS is a compact design that is built into two units. The Swept Source Engine (bottom unit) contains Thorlabs' Swept Source Laser and all associated drive electronics and controllers. The Imaging Module, which conveniently sits on top of the Engine, houses the OCT interferometer module, hand-held probe drive electronics, aiming beam, and user-adjustable reference arm and polarization control.

Dimensions

- Swept Source Engine: 12.6" x 10.6" x 5.9"
- Imaging Module: 12.6" x 10.6" x 2.6"

[Click Here to return to the top of the page.](#)



[Click to Enlarge](#)

Software

High-performance data acquisition software is included with all OCT systems. The Windows-based software performs data acquisition, processing, scan control, and display of OCT images. See the Software tab for more details.

A Software Development Kit (SDK) is also available for C/C++, Visual Basic, and LabVIEW-based interfaces. Please contact oct@thorlabs.com for more details.

[Click Here to return to the top of the page.](#)

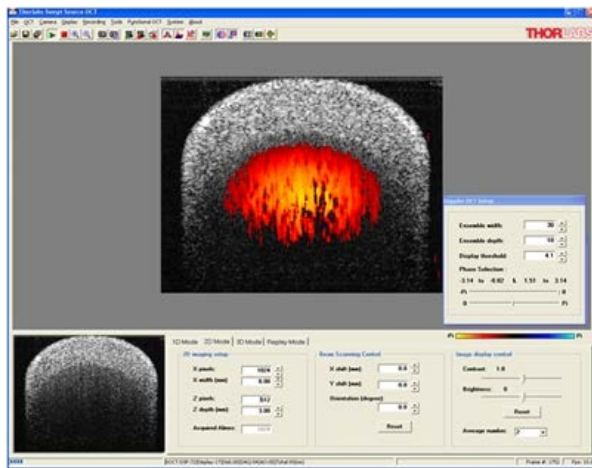

Click to Enlarge

Hand-Held Probe and Stand

All Thorlabs OCT systems include a hand-held probe and stand, as shown here. The probe provides X-Y scanning for three-dimensional data acquisition. A camera that is integrated in the probe provides live video imaging during OCT data acquisition. The probe easily slips onto the stand for imaging of small samples.

The probe stand consists of a post-mounted focus block which is attached to a specially designed 12" x 14" aluminum breadboard using a Ø1.5" DP14A Dynamically Damped Post.

Stand Features

- Ideal for Vibration-Sensitive Studies such as Doppler OCT Imaging
- 3/4" Thick Aluminum Breadboard Provides Increased Stability
- Breadboard Base has Side Grips and Recessed Feet for Easy Lifting and Transportation of the Stand
- Includes a Sample Stage with 1" X and Y Travel as well as Rotation

[Click Here to return to the top of the page.](#)



Click to Enlarge

[Hide Selection Guide](#)

SELECTION GUIDE

Thorlabs offers a wide variety of OCT imaging systems, each with their own special set of specifications. To assist in narrowing down which OCT system(s) is best suited for your application, we have provided the guide below. This information is intended only as a guide. We encourage you to contact us to discuss your specific imaging requirements.

[Contact Us](#)

	CALLISTO	GANYMEDE-II	GANYMEDE-II-HR	TELESTO-II	TELESTO-II-1325LR	OCS1310V1
Center Wavelength	930 nm (840 nm option also available)		900 nm	1300 nm	1325 nm	1300 nm
Bandwidth	100 nm ^a	100 nm ^a	150 nm ^a	170 nm ^a	100 nm ^a	100 nm ^b
A-Scan Line Rate	1.2 kHz	36 kHz		Up to 76 kHz		100 kHz
B-Scan Frame Rate ^{c,d}	2 fps	29 fps		Variable		110 fps
Depth Resolution ^e (Air)	7 µm	6 µm	3 µm	5.5 µm	12 µm	16 µm
Depth Resolution ^e (Water)	5.3 µm	4.3 µm	2.1 µm	4.2 µm	9.0 µm	12 µm
Lateral Resolution	8 µm	8 µm	4 µm	13 µm		25 µm
Sensitivity	105 dB	91 dB		Up to 103 dB		105 dB
Maximum Pixels per A-Scan	512	1024		1024		2048

Max Field of View^e (L x W x D)	10 x 10 x 1.7 mm	10 x 10 x 2.9 mm	6 x 6 x 1.9 mm	10 x 10 x 3.5 mm	10 x 10 x 7 mm	10 x 10 x 12 mm
--	------------------	------------------	----------------	------------------	----------------	-----------------

- Bandwidth at 3 dB
- Bandwidth at 20 dB
- Actual Frame Rate is dependent on processing and display parameters
- (512 lines/frame)
- Depth Resolution and actual imaging depth are dependent on the optical properties of the sample being imaged.

[Hide Software](#)

SOFTWARE

Software Index

OCS Swept Source Software:

- 1D Mode for OCT Interference Fringe Diagnosis
- 2D Mode for Cross-sectional Imaging
- 3D Mode for Volume Imaging
- Doppler Mode for Doppler Flow Imaging

OCS Swept Source Software

The pre-installed SS-OCT software contains everything needed for system control, data acquisition, processing, and file management. The software provides flexible control of image size, brightness, contrast, and the A-line average.

The OCT data may be displayed in 2D or 3D mode. The software allows real-time recording of 2D or 3D data into disk files at full imaging speed. For the 3D imaging mode, the probe beam is sequentially scanned across the sample surface area, and the 3D volume data set under this area is acquired, processed, and stored. 3D volume rendering capability of the data is provided with the preinstalled Matlab software. This package includes sample scripts for standard data collection and file management, but is also user-customizable.

The recorded binary data files can be exported into standard image files (jpeg, bmp) or converted to movie files (avi). A software program that provides 3D graphics rendering of acquired OCT data is also provided in the software package.

GUI

The screen captures for three different imaging modes of the software GUI are shown in the figures below. In the 1D imaging mode, there is no transverse scanning of the probe beam in the sample arm. The recalibrated interference fringe signals and the Fourier transformed point spread functions are displayed in real-time, which aids optimization of the signal and system parameters. In the 2D imaging mode, the probe beam is scanned in one direction and cross-sectional OCT images are displayed in real-time. In the 3D imaging mode, the probe beam sequentially scans multiple 2D images to build a volume stack. Online rendering algorithms enable 3D visualization of the acquired volume stack as well as extracting slices in the three orthogonal orientations.

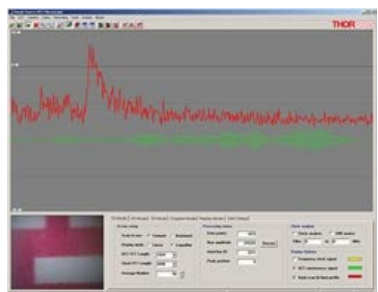

Click to Enlarge

Figure 1a: The 1D mode used for OCT interference fringe diagnosis.

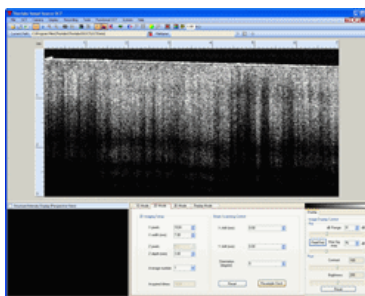

Click to Enlarge

Figure 1b: The 2D mode for cross-sectional imaging.

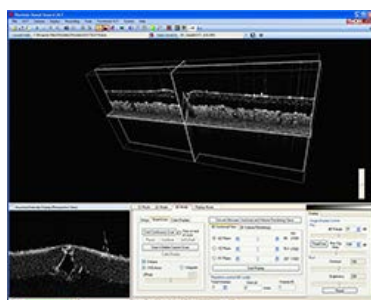

Click to Enlarge

Figure 1c: The 3D volume imaging mode.

Doppler Imaging Mode

Thorlabs Swept Source OCT System includes Doppler Imaging capability to allow simultaneous OCT imaging with real-time flow monitoring, which is ideal for microfluidics, vascular or developmental biology studies.

To the right is a screen shot of the Doppler Software user interface showing an overlay of Doppler and structural OCT images. This software provides other display options of the Doppler image as well as user control of functions such as display thresholding. Please see our Publications list for applications utilizing our Doppler OCT imaging capability.

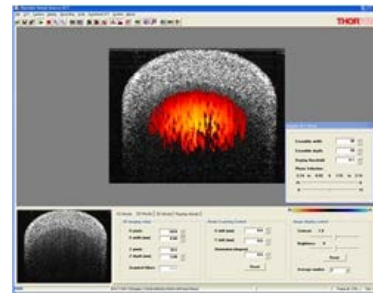

Click to Enlarge

Figure 2: The 3D volume imaging mode.

[Hide Doppler OCT](#)

DOPPLER OCT

Doppler OCT Imaging

Doppler OCT is an extension of OCT that enables imaging of particle motion within a sample. In Fourier Domain OCT (FD-OCT) systems, there are no additional hardware requirements for implementation of Doppler imaging. Doppler OCT imaging capability is embedded in the software provided with all Thorlabs' OCT systems and is ideal for functional vascular imaging, studying embryonic cardiac dynamics, or monitoring vascular treatment response. It is also useful for general flow velocimetry used in microfluidic channel monitoring.

Principles of Doppler OCT

The Fourier transform of the interferogram acquired in FD-OCT imaging (A-scan) produces a complex signal $[I(z) + iQ(z)]$, where the magnitude of that signal is used to create the structural OCT image. The complex portion of the signal contains information based on the phase of the interferogram. Any change in phase between consecutively acquired A-scans can be attributed to a Doppler frequency shift induced by particle motion.

In Thorlabs' implementation of Doppler OCT, Doppler frequency shifts are calculated based on spatially averaging phase shifts within a sliding 2D window and using a Kasai autocorrelation function (see reference below). The Doppler frequency shift f_D caused by moving particles is related to the phase shift between A-scans, as described in the following expression:

$$f_D = \frac{\Delta\phi}{2\pi} f_A$$

Reference:

C. Kasai, K. Namekawa, A. Koyano, R. Omoto et al. "Realtime two-dimensional blood flow imaging using an autocorrelation technique," *IEEE Trans. Sonics. Ultrason.* 32 458-464 (1985).

where $\Delta\phi$ is the average phase shift within the sliding 2D window and f_A is the A-scan rate of the OCT system. The Thorlabs Doppler Imaging Mode displays the phase shift induced by moving particles using a standard Doppler colormap where red to yellow (violet to blue) indicates flow in the direction toward (away from) the OCT sample beam.

The mean velocity $\langle v \rangle$ of the moving particles, at any depth, can be quantified by knowing θ , the angle between the OCT sample beam and flow vector:

$$\langle v \rangle = \frac{\lambda_o f_D}{2n \cos(\theta)}$$

Here, λ_o is the center optical wavelength of the OCT sample beam and n is the index of refraction of the sample.

Doppler Effect

A stationary observer will observe a Doppler shift in the frequency of light emitted from a source moving toward or away from the observer. When the light source is moving toward the observer, the observed frequency of light will be blue-shifted, meaning the perceived frequency of the light will be higher than the actual frequency emitted by the source. Higher frequencies correspond to shorter wavelengths. Conversely, if the light source is moving away from the observer, the observed frequency of light will be redshifted to lower frequencies. In Doppler OCT, the Doppler effect caused by moving particles in a sample is determined by measuring a shift in the phase between consecutive OCT interference fringe signals.

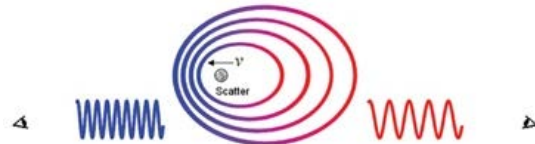

Click to Enlarge

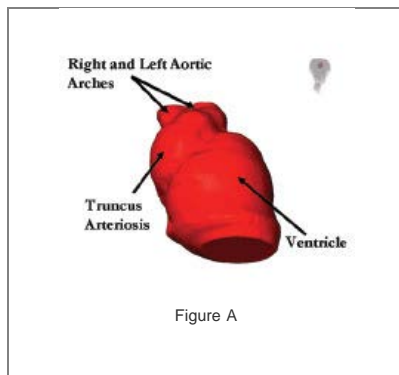

Figure A

Developmental Biology

Thorlabs' Swept Source OCT Imaging System (OCS1300SS) with Doppler Imaging was used by researchers at the University of Toronto to study the cardiovascular system of living tadpoles. The series of images below show *in vivo* cross-sectional SS-OCT images of a beating tadpole heart superimposed with Doppler blood flow images. An optical Doppler cardiogram was obtained using a gated technique to increase the effective frame rate and improve the signal-to-noise ratio. The gating technique provides ultra high-speed visualization of the heart blood flow pattern in developing African frog embryos in both 3D and 4D (i.e., 3D + time) modes. This allows detailed visualization of the complex cardiac motion and hemodynamics in the beating heart.

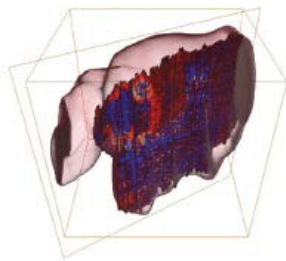
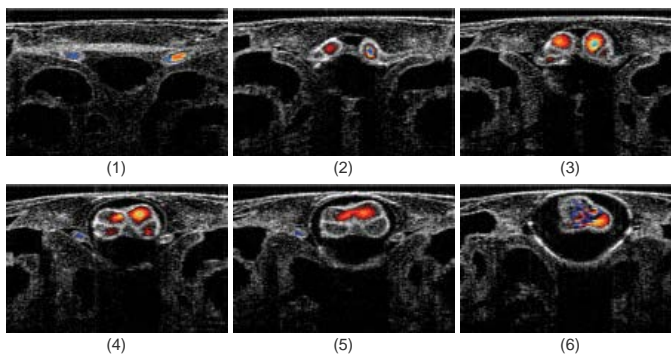

Figure B

Fig. A shows the 3D surface reconstruction of the tadpole heart, while Fig. B demonstrates the complex blood flow pattern of the heart via a 3D color Doppler map.



Reference:

A. Mariampillai, B.A. Standish, N.R. Munce, C. Randall, G. Liu, J.Y. Jiang, A.E. Cable, I.A. Vitkin, V.X.D. Yang, "Doppler optical cardiogram gated 2D color flow imaging at 1000 fps and 4D in vivo visualization of embryonic heart at 45 fps on a swept source OCT system", Optics Express 15, 1627 (2007).

[Hide Tutorial](#)

TUTORIAL

Optical Coherence Tomography Tutorial

Optical Coherence Tomography (OCT) is a noninvasive optical imaging modality that provides real-time, 1D depth, 2D cross-sectional, and 3D volumetric images with micron-level resolution and millimeters of imaging depth. OCT images consist of structural information from a sample based on light backscattered from different layers of material within the sample. It can provide real-time imaging and is capable of being enhanced using birefringence contrast or functional blood flow imaging with optional extensions to the technology.

Thorlabs has designed a broad range of OCT imaging systems that cover several wavelengths, imaging resolutions, and speeds, while having a compact footprint for easy portability. Also, to increase our ability to provide OCT imaging systems that meet each customer's unique requirements, we have designed a highly modular technology that can be optimized for varying applications.

Application Examples

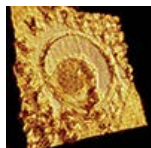

Art Conservation

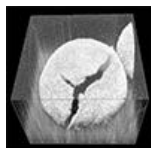

Drug Coatings



3D Profiling

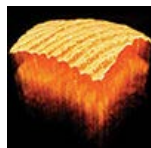

In-vivo

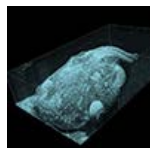

Small Animal

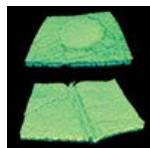

Biology

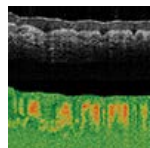

Tissue Birefringence



Mouse Lung

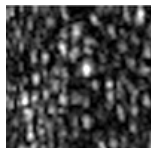

Retina Cone Cells

OCT is the optical analog of ultrasound, with the tradeoff being lower imaging depth for significantly higher resolution (see Figure 1). With up to 15 mm imaging range and better than 5 micrometers in axial resolution, OCT fills a niche between ultrasound and confocal microscopy.

In addition to high resolution and greater imaging depth, the non-contact, noninvasive advantage of OCT makes it well suited for imaging samples such as biological tissue, small animals, and materials. Recent advances in OCT have led to a new class of technologies called Fourier Domain OCT, which has enabled high-speed imaging at rates greater than 700,000 lines per second.¹

Fourier Domain Optical Coherence Tomography (FD-OCT) is based on low-coherence interferometry, which utilizes the coherent properties of a light source to measure optical path length delays in a sample. In OCT, to obtain cross-sectional images with micron-level resolution, and interferometer is set up to measure optical path length differences between light reflected from the sample and reference arms.

There are two types of FD-OCT systems, each characterized by its light source and detection schemes: Spectral Domain OCT (SD-OCT) and

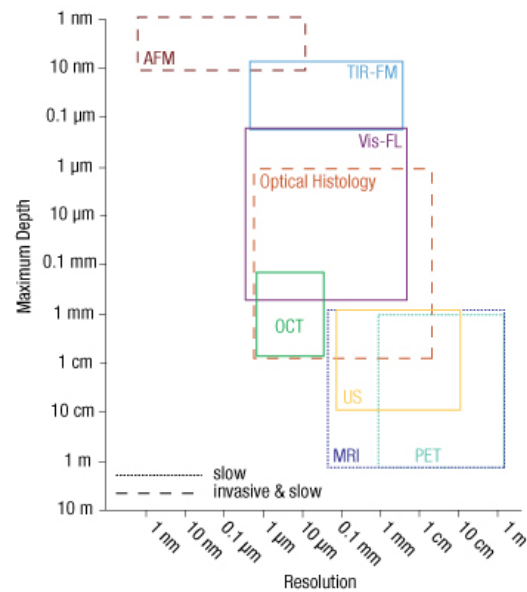

Click to Enlarge
Figure 1

Swept Source OCT (SS-OCT). In both types of systems, light is divided into sample and reference arms of an interferometer setup, as illustrated in Fig 2. SS-OCT uses coherent and narrowband light, whereas SD-OCT systems utilize broadband, low-coherence light sources. Back scattered light, attributed to variations in the index of refraction within a sample, is recoupled into the sample arm fiber and then combined with the light that has traveled a fixed optical path length along the reference arm. A resulting interferogram is measured through the detection arm of the interferometer.

The frequency of the interferogram measured by the sensor is related to depth locations of the reflectors in the sample. As a result, a depth reflectivity profile (A-scan) is produced by taking a Fourier transform of the detected interferogram. 2D cross-sectional images (B-scans) are produced by scanning the OCT sample beam across the sample. As the sample arm beam is scanned across the sample, a series of A-scans are collected to create the 2D image.

Similarly, when the OCT beam is scanned in a second direction, a series of 2D images are collected to produce a 3D volume data set. With FD-OCT, 2D images are collected on a time scale of milliseconds, and 3D images can be collected at rates now below 1 second.

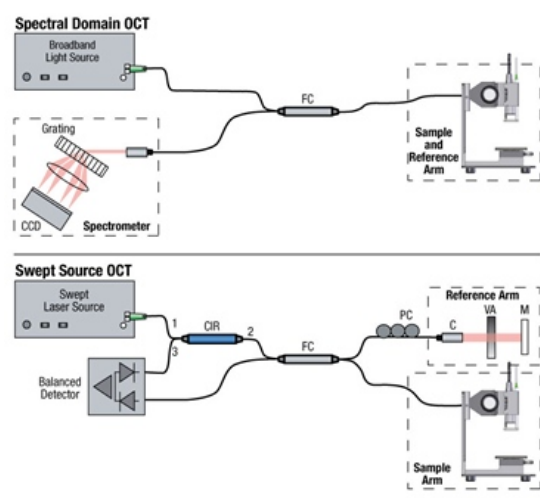

Click to Enlarge
Figure 2

Spectral Domain OCT vs. Swept Source OCT

Spectral Domain and Swept Source OCT systems are based on the same fundamental principle but incorporate different technical approaches for producing the OCT interferogram. SD-OCT systems have no moving parts and therefore have high mechanical stability and low phase noise. Availability of a broad range of line cameras has also enabled development of SD-OCT systems with varying imaging speeds and sensitivities.

SS-OCT systems utilize a frequency swept light source and photodetector to rapidly generate the same type of interferogram. Due to the rapid sweeping of the swept laser source, high peak powers at each discrete wavelength can be used to illuminate the sample to provide greater sensitivity with little risk of optical damage.

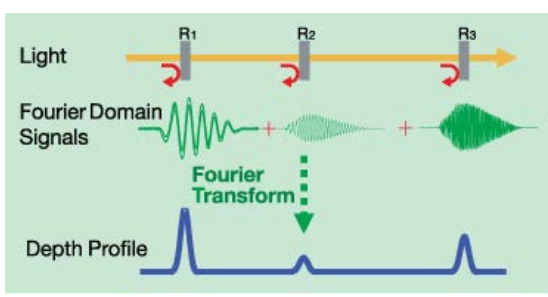

Click to Enlarge

FD-OCT Signal Processing

In Fourier Domain OCT, the interferogram is detected as a function of optical frequency. With a fixed optical delay in the reference arm, light reflected from different sample depths produces interference patterns with the different frequency components. A Fourier transform is used to resolve different depth reflections, thereby generating a depth profile of the sample (A-scan).

¹ V. Jayaraman, J. Jiang, H.Li, P. Heim, G. Cole, B. Potsaid, J. Fujimoto, and A. Cable, "OCT Imaging up to 760 kHz Axial Scan Rate Using Single-Mode 1310

nm MEMs-Tunable VCSELs with 100 nm Tuning Range," CLEO 2011 - Laser Applications to Photonic Applications, paper PDPB2 (2011).

[Hide Related Products](#)

RELATED PRODUCTS

Related Products

 <p>OCT System Comparison</p>	 <p>Microscope Module</p>	 <p>Polarization-Sensitive Module</p>
 <p>Swept Source Lasers</p>	 <p>Scan Lenses</p>	 <p>OCT Balanced Detectors</p>
 <p>OCT Interferometers</p>	 <p>OCT Fiber Collimators</p>	 <p>OCT Fiber Components</p>

[Hide Part Numbers](#)

Part Number	Description	Price	Availability
OCS1300SS	Optical Coherence System, 1300 nm, Swept Source	\$60,000.00	Lead Time

Visit the [Swept Source OCT Systems](#) page for pricing and availability information:
http://www.thorlabs.com/newgrouppage9.cfm?objectgroup_id=2098