

For current pricing, please see our website.

CHAPTERS

Optical Elements

Polarization Optics

Optical Isolators

Optical Systems

Optics Kits

SECTIONS

Beam Expanders

Objective/Scan Lenses

Camera Lenses

Interferometers

Scanning Galvo Mirror System

Free-Space EO Modulators

Reference Cells

Quartz Reference Cells

Thorlabs' quartz reference cells are offered with UV fused silica windows for superior transmission in the UV spectral range. The windows are wedged with a 2° angle to minimize the etalon effect present with flat windows. Furthermore, these wedged windows are welded to the cell at 11° to minimize the beam offset that would normally be present with a wedged window. The quartz cells can be filled with water, iodine, cesium, or rubidium. The Rubidium reference cell (CQ19075-RB) is sold with the natural isotope ratio of Rb, which is 72.15% ⁸⁵Rb and 27.85% ⁸⁷Rb. Versions are also available with 98% pure ⁸⁵Rb (CQ19075-RB85) or 98% pure ⁸⁷Rb (CQ19075-RB87).

The quartz reference cells are tested for off-resonance transmission and fill material purity. The standard reference cells are evacuated before the fill material is added, and the cell is sealed under vacuum so that the fill material is the only material inside the cell. However, the reference cells can be ordered with the fill material and a buffer gas at a specified pressure. The noble gases or nitrogen are commonly chosen buffer gases. The presence of a buffer gas will cause the center wavelength of the absorption lines to shift and the width of the absorption lines to broaden.

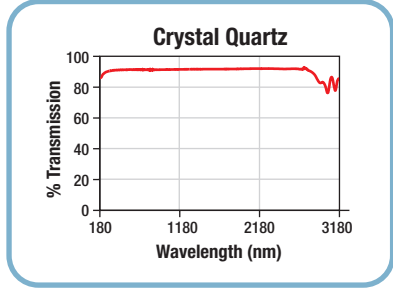

Specifications

- **Window Material:** UV Fused Silica
- **Cell Diameter:** 19 mm
- **Fill Stem:** <10 mm
- **Window Angle:** 11° ± 1°
- **Window Wedge Angle:** 2°
- **Window Thickness:** 2 mm
- **Window Surface Quality:** 60-40 Scratch-Dig
- **Window Flatness:** λ/4
- **Fill Pressure Temperature:** 25 °C

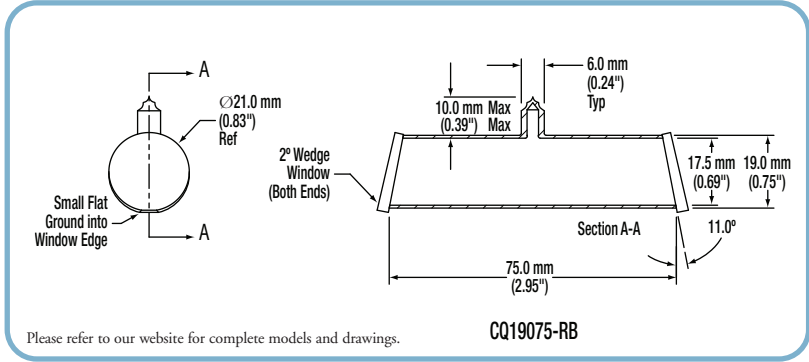

Please refer to our website for complete models and drawings.

ITEM #	\$	£	€	RMB	FILL PRESSURE	TEMPERATURE	DESCRIPTION
CQ19075-RB	\$ 584.00	£ 420.48	€ 508.08	¥ 4,654.48	1 x 10 ⁻⁷ Torr	25 °C	Quartz Ref. Cell, Ø19 x 75 mm, Rubidium (Rb)
CQ19075-RB85	\$ 1,065.00	£ 766.80	€ 926.55	¥ 8,488.05	1 x 10 ⁻⁷ Torr	25 °C	Quartz Ref. Cell, Ø19 x 75 mm, Rubidium (⁸⁵ Rb)
CQ19075-RB87	\$ 1,020.00	£ 734.40	€ 887.40	¥ 8,129.40	1 x 10 ⁻⁷ Torr	25 °C	Quartz Ref. Cell, Ø19 x 75 mm, Rubidium (⁸⁷ Rb)
CQ19075-CS	\$ 584.00	£ 420.48	€ 508.08	¥ 4,654.48	1 x 10 ⁻⁷ Torr	25 °C	Quartz Ref. Cell, Ø19 x 75 mm, Cesium (Cs)
CQ19075-H2O	\$ 584.00	£ 420.48	€ 508.08	¥ 4,654.48	4 Torr	25 °C	Quartz Ref. Cell, Ø19 x 75 mm, Water (H ₂ O)
CQ19100-I	\$ 584.00	£ 420.48	€ 508.08	¥ 4,654.48	0.3 Torr	25 °C	Quartz Ref. Cell, Ø19 x 100 mm, Iodine (I ₂)

Have you seen our...



Frequency Stabilized Tunable External Cavity Lasers

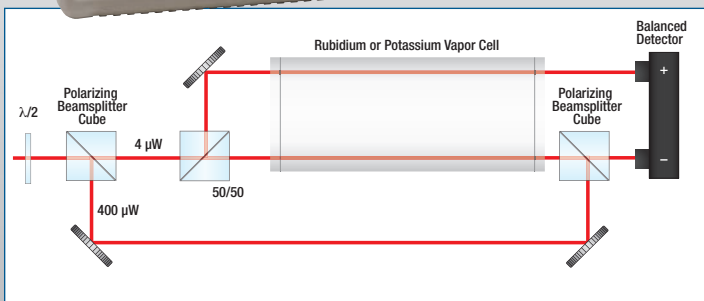

Thorlabs' frequency-stabilized laser systems, which include both stabilization electronics and a laser source, extend our line of tunable diode lasers by providing an option for stabilizing the laser output to an atomic transition frequency. Stabilized light sources are frequently used in atomic physics applications such as the cooling and trapping of rubidium atoms. Dichroic Atomic Vapor Spectroscopy (DAVS) and Saturated Absorption Spectroscopy (SAS) Systems are available.

For more details, see page 1284