

KPZNFL5 - February 27, 2024

Item # KPZNFL5 was discontinued on February 27, 2024. For informational purposes, this is a copy of the website content at that time and is valid only for the stated product.

SINGLE-AXIS FLEXURE TRANSLATION STAGES: 5 MM TRAVEL

- Differential Adjusters
- Optional 20 μm Piezo Drive for Open- or Closed-Loop Operation
- Mounting Plate & Angle Bracket Accessories



NFL5DP20S
Shown with NFL5P1
Baseplate (Not Included)



NFL5P1
Base Plate



Typical XZ
Configuration

[Hide Overview](#)

OVERVIEW

Features

- Differential Adjuster
Translation Range:
5 mm
- Optional 20 μm Piezo Drive
 - NFL5DP20(M): Open-Loop Operation
 - NFL5DP20S(M): Strain Gauge for Closed-Loop Operation
- Compact Size: 3.00" (75 mm) Square, 1.18" (30 mm) Thick
- XYZ-Configurable
- NFL5DP20 Open-Loop Stage Available Bundled with KPZ101 Controller (See *Bundle* Tab for Details)

When stability is of the utmost importance, the NanoFlex™ 5 mm travel single-axis compound flexure stages provide ultra-smooth translation for applications that are intolerant to the errors inherent in linear bearings. The compound linear symmetrical flexure design ensures true linear motion with zero cross talk over the full range of translation. This is achieved without the use of parts that require controlled contact to maintain their function; all the motion results from the flexing of various structural components within the translator. These features provide uncompromised performance, even when used in harsh environments.

Single-Axis Flexure Stage Selection Guide	
Translation Range:	1.5 mm Travel
	5 mm Travel

Item #	Key Specifications		
	NFL5D(M)	NFL5DP20(M)	NFL5DP20S(M)
Actuator(s)	Differential Micrometer	Diff. Micrometer & Open-Loop Piezo	Diff. Micrometer & Closed-Loop Piezo
Coarse Adjuster Travel	5 mm (0.20")		
Coarse Adjuster Resolution	0.5 mm per Revolution		
Fine Adjuster Travel	300 μm		
Fine Adjuster Resolution	50 μm per Revolution		
Load Capacity	Horizontal: 1 kg (2.2 lbs) Vertical: 0.5 kg (1.1 lbs)		
Piezo Travel	N/A	20 μm	20 μm
Piezo Resolution (Theoretical)	N/A	0.6 nm	0.6 nm ^b
Piezo Voltage	N/A	0 - 75 V	0 - 75 V

- a. Refer to the *Specs* tab for complete specifications.
- b. Closed-Loop Operation Using Strain Gauge Position Sensor

These stages can be stacked in a 2-axis or 3-axis configuration using the optional base plate NFL5P1(M) and angle bracket NFL5P2(M) described below. A 3 m long SMC to SMC piezo drive cable is supplied with the open-loop and closed-loop piezo versions. The closed-loop NFL5DP20S(M) also includes a 3 m long LEMO

to D-Type feedback cable (Item # PAA622). See the *Pin Diagrams* tab for connector details.

See the *Specs* tab above for more detailed information on the stages, including compatible controllers. We offer the NFL5DP20 stage bundled with a controller at a discounted price below. See the *Bundle* tab for more information on this bundle. A power supply is not included; compatible power supplies are sold separately below.

[Hide Specs](#)

SPECS

Item #	NFL5D(/M)	NFL5DP20(/M)	NFL5DP20S(/M)
Stage Specifications			
Manual Travel Range	5 mm (0.20")	5 mm (0.20")	5 mm (0.20")
Maximum Stage Load Capacity	Horizontal: 1 kg (2.2 lbs) Vertical: 0.5 kg (1.1 lbs)	Horizontal: 1 kg (2.2 lbs) Vertical: 0.5 kg (1.1 lbs)	Horizontal: 1 kg (2.2 lbs) Vertical: 0.5 kg (1.1 lbs)
Stage Mounting Surface Dimensions	75 mm x 75 mm (2.95" x 2.95")	75 mm x 75 mm (2.95" x 2.95")	75 mm x 75 mm (2.95" x 2.95")
Stage Height	30 mm (1.18")	30 mm (1.18")	30 mm (1.18")
Manual Drive Specifications			
Drive Type	Differential Micrometer	Differential Micrometer	Differential Micrometer
Coarse Adjustment Pitch	0.5 mm	0.5 mm	0.5 mm
Fine Adjustment Range	300 µm	300 µm	300 µm
Fine Adjustment Pitch	50 µm	50 µm	50 µm
Piezo Specifications			
Voltage	N/A	0 to 75 V	0 to 75 V
Position Sensor for Closed-Loop Operation	N/A	N/A	Strain Gauge
Travel Range	N/A	20 µm	20 µm
Theoretical Resolution	N/A	0.6 nm ^a	0.6 nm ^a (Closed-Loop Operation)
Capacitance	N/A	3.6 µF	3.6 µF
Connector	N/A	Male SMC	Male SMC
Feedback Connector	N/A	N/A	Male 7 Pin LEMO
Cable Length	N/A	SMC to SMC: 3 m (9.84')	SMC to SMC: 3 m (9.84') LEMO to D-Type: 3 m (9.84')
Recommended Controllers	N/A	KPZ101, MDT694B, or MPZ601	BPC301, MPZ601, or KPZ101 and KSG101

a. When Driven by the KPZ101, BPC301 or MPZ601 Controllers

[Hide Pin Diagrams](#)

PIN DIAGRAMS

Piezo Drive Input NFL5DP20(/M) and NFL5DP20S(/M)

SMC Male



Nominal maximum input voltage: 75 V
Absolute maximum input voltage: 100 V

Pin	Designation
1	Bridge
2	+15 V
3	-15 V
4	0 V
5	Signal
6	0 V
7	Ident
8	Not Connected
9	Not Connected

Displacement Sensor NFL5DP20S(/M) Only

7 Pin LEMO Male (Stage)



9 Pin D-Type Male (Feedback Cable)

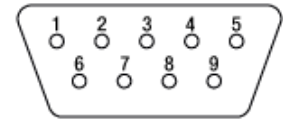

[Hide Bundle](#)

BUNDLE

Stage and Controller Bundle

The KPZNFL5 bundle includes the NFL5DP20 stage, KPZ101 K-Cube piezo controller, USB cable, piezo drive cable, and NFL5P1 mounting plate. The stage provides 5 mm of total translation via a differential micrometer. For finer adjustment, the piezo drive offers 20 μm of translation with 0.6 nm resolution. This bundle is offered at 10% savings over the individual components.

K-Cube Piezo Controller

The KPZ101 can be controlled by its top panel for standalone operation or through its PC interface. The KPZ101 connects to a PC via a mini USB port (USB cable included) and utilizes Thorlabs' Kinesis[®] software or former generation APT[™] software. The Kinesis software features an intuitive graphical user interface (GUI) that allows the unit to be controlled completely via a PC. For more demanding applications, customers can utilize ActiveX[®] or .NET programming to create their own software for Thorlabs' line of K-Cubes. See the *Motion Control Software* tab for more information.

Power Supplies

The KPZ101 does not include a power supply as our customers have varying needs. Please see the compatible power supplies below.

Item #	KPZNFL5
NFL5DP20 Stage Specifications	
Drive Type	Differential Micrometer & Piezo
Travel Range	5 mm (0.20")
Load Capacity	Horizontal: 1 kg (2.2 lbs) Vertical: 0.5 kg (1.1 lbs)
Coarse Adjustment Pitch	0.5 mm
Fine Adjustment Range	300 μm
Fine Adjustment Pitch	50 μm
Piezo Travel Range	20 μm
Piezo Resolution	0.6 nm
Piezo Voltage	0 to 75 V
KPZ101 Controller Specifications	
Drive Voltage	0 to 150 V
Drive Current, Max, Continuous	7.5 mA
Stability	100 ppm Over 24 hrs (After 30 min Warm-Up)
Noise	<2 mV _{RMS}
Typical Piezo Capacitance	1 to 10 μF
Bandwidth	1 kHz (1 μF Load, 1 V _{p-p})
External Input (SMA Male)	0 to 10 V
Output Monitor (SMA Male)	0 to 10 V
USB Port	USB 2.0 ^a

- a. The USB 3.0 port is compatible with a USB 2.0 Micro B connector if the Micro B connector is plugged into the shaded region depicted in this diagram. A USB 3.0 type A to type Micro B cable is included with the KPZ101.

[Hide Motion Control Software](#)

MOTION CONTROL SOFTWARE

Thorlabs offers two platforms to drive our wide range of motion controllers: our Kinesis[®] software package or the legacy APT[™] (Advanced Positioning Technology) software package. Either package can be used to control devices in the Kinesis family, which covers a wide range of motion controllers ranging from small, low-powered, single-channel drivers (such as the K-Cubes[™] and T-Cubes[™]) to high-power, multi-channel, modular 19" rack nanopositioning systems (the APT Rack System).

The Kinesis Software features .NET controls which can be used by 3rd party developers working in the latest C#, Visual Basic, LabVIEW[™], or any .NET compatible languages to create custom applications. Low-level DLL libraries are included for applications not expected to use the .NET framework. A Central Sequence Manager supports integration and synchronization of all Thorlabs motion control hardware.

Our legacy APT System Software platform offers ActiveX-based controls which can be used by 3rd

party developers working on C#, Visual Basic, LabVIEW™, or any Active-X compatible languages to create custom applications and includes a simulator mode to assist in developing custom applications without requiring hardware.

By providing these common software platforms, Thorlabs has ensured that users can easily mix and match any of the Kinesis and APT controllers in a single application, while only having to learn a single set of software tools. In this way, it is perfectly feasible to combine any of the controllers from single-axis to multi-axis systems and control all from a single, PC-based unified software interface.

The software packages allow two methods of usage: graphical user interface (GUI) utilities for direct interaction with and control of the controllers 'out of the box', and a set of programming interfaces that allow custom-integrated positioning and alignment solutions to be easily programmed in the development language of choice.

A range of video tutorials is available to help explain our APT system software. These tutorials provide an overview of the software and the APT Config utility. Additionally, a tutorial video is available to explain how to select simulator mode within the software, which allows the user to experiment with the software without a controller connected. Please select the *APT Tutorials* tab above to view these videos.

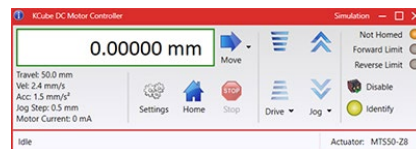

Kinesis GUI Screen

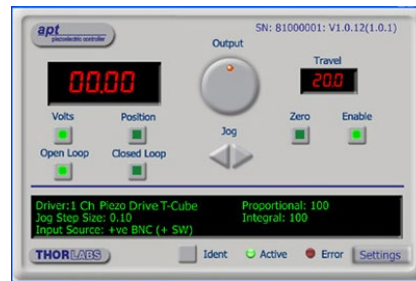

APT GUI Screen

Software

Kinesis Version 1.14.47

The Kinesis Software Package, which includes a GUI for control of Thorlabs' Kinesis and APT™ system controllers.

Also Available:

- Communications Protocol



Software

APT Version 3.21.6

The APT Software Package, which includes a GUI for control of Thorlabs' APT™ and Kinesis system controllers.

Also Available:

- Communications Protocol



[Hide Manual Linear Stages](#)







MANUAL LINEAR STAGES

Manual Linear Translation Stages

Thorlabs' manual translation stages are offered in a range of maximum travel distances, from less than 1/4" (6 mm) to 2" (50 mm) and longer for our long travel, large area platforms. Many of these stages can be ordered in multi-axis configurations, providing XY or XYZ translation. For fiber coupling applications, please see our Multi-Axis Stages, which offer finer adjustment than our standard manual translation stages. In addition to linear translation stages, we offer rotation stages, pitch and yaw platforms, and goniometers. We also offer motorized translation stages that are powered by DC Servo motors, stepper motors, or direct drive technology.

Crossed-Roller Bearing Stages

These linear translation stages feature crossed-roller bearing travel mechanisms for precision motion, high load capacity, and low angular deviation. The LNR Series stages feature all-steel body construction, while the LX, XRN, and XR Series stage bodies are constructed of cast tool and jig aluminum. We also offer several vertical crossed-roller bearing stages (see below).

Crossed-Roller Bearing Stages						
Product Family	LNR Series 25 mm Stages	LX Series 25 mm Stages	XRN Series 25 mm Stages	XR Series 25 mm Stages	XR Series 50 mm Stages	LNR Series 50.8 mm Stages
Click Photo to Enlarge						
Travel	25 mm (0.98")	25 mm (0.98")	25 mm (0.98")	25 mm (0.98")	50 mm (1.97")	50.8 mm (2")
Drive Type	Multiple	Micrometer	Micrometer	Micrometer	Micrometer	Multiple
Platform Size	2.34" x 2.36"	2.56" x 2.56" (65.0 mm x	2.00" x 3.35"	2.98" x 4.33"	2.98" x 5.51"	3.94" x 3.94"

	(59.4 mm x 60.0 mm)	65.0 mm)	(50.7 mm x 85.0 mm)	(75.7 mm x 110.0 mm)	(75.7 mm x 140.0 mm)	(100.0 mm x 100.0 mm)
Possible Axis Configurations	X, XZ, XY, XYZ	X, XY, XZ, YZ, XYZ	X, Y, Z, XY, XZ, YZ, XYZ	X, Y, Z, XY, XZ, YZ, XYZ	X, Y, Z, XY, XZ, YZ, XYZ	X, XY, XYZ
Additional Details						



Ball Bearing Stages

These translation stages feature hardened steel linear bearings for precise motion and long life. They are available with a variety of actuators and in single-axis or preassembled multi-axis configurations.

Ball Bearing Stages					
Product Family	MS Series 1/4" Stages	T12 Series 1/2" Stages	MT Series 1/2" Stages	PT Series 1" Stages	LT Series 2" Stages
Click Photo to Enlarge					
Travel	1/4" (6.4 mm)	1/2" (12.7 mm)	1/2" (12.7 mm)	1" (25.4 mm)	2" (50 mm)
Drive Type	Multiple	Thumbscrew	Multiple	Multiple	Differential Micrometer
Platform Size	1.17" x 1.17" (29.7 mm x 29.7 mm)	0.76" x 0.81" (19.3 mm x 20.6 mm)	2.40" x 2.41" (61.0 mm x 61.2 mm)	3.00" x 4.00" (76.2 mm x 101.6 mm)	3.75" x 3.75" (95.3 mm x 95.3 mm)
Possible Axis Configurations	X, XY, XYZ	X, XY, XYZ	X, XY, XYZ	X, XY, XYZ	X, XY, XYZ
Additional Details					

Dovetail Stages





These compact stages incorporate dovetails and a leadscrew for the translation mechanism. They are suitable in general purpose motion control applications.

Dovetail Stages			
Product Family	DT Series 1/2" Stages	DTS Series 1" Stage	DTS Series 2" Stage
Click Photo to Enlarge			
Travel	1/2" (12.7 mm)	1" (25 mm)	2" (50 mm)
Drive Type	Thumbscrew	Thumbscrew	Thumbscrew
Platform Size	1.00" x 1.00" (25.4 mm x 25.4 mm)	2.68" x 2.95" (68.0 mm x 75.0 mm)	2.68" x 3.74" (68.0 mm x 95.0 mm)
Possible Axis Configurations	X, XY, XYZ	X, XY, XYZ	X, XY, XYZ
Additional Details			

Flexure Stages







Thorlabs' Nanoflex™ translation stages feature frictionless flexure mechanisms for improved positioning and resolution when compared to similar stages made using bearings. The translation of the stage is accomplished by the elastic deformation (flexing) of a linkage attached to the mounting platform. Most models also include piezo actuators for small position adjustments.

Flexure Stages			
Product Family	Nanoflex™ 1.5 mm Stage	Nanoflex™ 5 mm Stages	
Click Photo to Enlarge			

				
Travel	1.5 mm (0.06") + 25 µm Piezo	5 mm (0.20")	5 mm (0.20") + 20 µm Piezo	
Drive Type	Thumbscrew and Piezo Actuator	Differential Micrometer	Differential Micrometer and Open-Loop Piezo Actuator	Differential Micrometer and Closed-Loop Piezo Actuator
Platform Size	1.18" x 1.18" (30.0 mm x 30.0 mm)	2.95" x 2.95" (75.0 mm x 75.0 mm)		
Possible Axis Configurations	X, XY, XYZ	X, XY, XYZ	X, XY, XYZ	X, XY, XYZ
Additional Details				

Vertical Stages

We offer vertical translation stages with crossed-roller bearings for precise motion as well as long travel vertical stages for heavy-duty applications.

Vertical Stages						
Product Family	XRN Series 9 mm Vertical Stage	XR Series 14 mm Vertical Stage	MVS Series 1/2" Vertical Stage	MVS Series 1" Vertical Stage	VAP Series 4" Vertical Stage	VAP Series 10" Vertical Stage
Click Photo to Enlarge						
Travel	9.0 mm (0.35")	14.0 mm (0.55")	1/2" (13.0 mm)	1" (25.0 mm)	4" (101.6 mm)	10" (254 mm)
Drive Type	Worm-Gear Driven Lift Screw		Micrometer		Adjuster Knob and Coarse Manual Positioning	
Platform Size	2.00" x 2.00" (50.7 mm x 50.7 mm)	2.98" x 2.98" (75.7 mm x 75.7 mm)	2.36" x 2.36" (60.0 mm x 60.0 mm)		3.00" x 6.00" (76.2 mm 152.4 mm)	
Additional Details						

[Hide Motorized Linear Stages](#)

MOTORIZED LINEAR STAGES







Motorized Linear Translation Stages

Thorlabs' motorized linear translation stages are offered in a range of maximum travel distances, from a stage with 20 µm of piezo translation to our 600 mm direct drive stage. Many of these stages can be assembled in multi-axis configurations, providing XY or XYZ translation. For fiber coupling applications, please see our multi-axis stages, which offer finer adjustment than our standard motorized translation stages. In addition to motorized linear translation stages, we offer motorized rotation stages and goniometers. We also offer manual translation stages.





Piezo Stages

These stages incorporate piezoelectric elements in a variety of drive mechanisms. ORIC® stages incorporate piezo inertia drives that use "stick-slip" friction properties to obtain extended travel ranges. Our Nanoflex™ translation stages use standard piezo chips along with manual actuators. Elliptec® stages use resonant piezo motors to push and pull the moving platform through resonant elliptical motion. Our LPS710E z-axis stage features a mechanically amplified piezo design and includes a matched controller.

Piezoelectric Stages						
Product Family	ORIC® PD2 Open-Loop 5 mm Stage	ORIC® PDX2 Closed-Loop 5 mm Stage	ORIC® PD1 Open-Loop 20 mm Stage	ORIC® PD1D Open-Loop 20 mm Monolithic XY Stage	ORIC® PDX1 Closed-Loop 20 mm Stage	ORIC® PD3 Open-Loop 50 mm Stage
Click Photo to Enlarge						

						
Travel	5 mm		20 mm			50 mm
Maximum Velocity	10 mm/s ^a	8 mm/s (Typ.) ^b	3 mm/s ^c		20 mm/s ^b	10 mm/s ^a
Drive Type	Piezoelectric Inertia Drive					
Possible Axis Configurations	X, XY, XYZ		X, XY, XYZ	XY, XYZ	X, XY, XYZ	X, XY, XYZ
Mounting Surface Size	13 mm x 13 mm		30 mm x 30 mm			80 mm x 30 mm
Additional Details						

- a. Specified using PDXC and PDXC2 Benchtop Controllers. For performance when controlled with a KIM001 or KIM101 K-Cube Controller, see the *Specs* tab of the PD2 or PD3 stage presentation.
- b. Specified using PDXC and PDXC2 Benchtop Controllers.
- c. Specified using KIM101 K-Cube Controller.





Piezoelectric Stages					
Product Family	Nanoflex™ 20 µm Stage with 5 mm Actuator	Nanoflex™ 25 µm Stage with 1.5 mm Actuator	Elliptec® 28 mm Stage	Elliptec® 60 mm Stage	LPS710E 1.1 mm Vertical Stage
Click Photo to Enlarge					
Travel	20 µm + 5 mm Manual	25 µm + 1.5 mm Manual	28 mm	60.0 mm	1.1 mm
Maximum Velocity	-		180 mm/s	90 mm/s	-
Drive Type	Piezo with Manual Actuator		Resonant Piezoelectric Motor		Amplified Piezo
Possible Axis Configurations	X, XY, XYZ		X		Z
Mounting Surface Size	75 mm x 75 mm	30 mm x 30 mm	15 mm x 15 mm		21 mm x 21 mm
Additional Details					

Stepper Motor Stages

These translation stages feature removable or integrated stepper motors and long travel ranges up to 300 mm. Many of these stages either have integrated multi-axis capability (PLSXY) or can be assembled into multi-axis configurations (PLSX, LNR Series, NRT Series, and LTS Series stages). The MLJ150 stage also offers high load capacity vertical translation.





Stepper Motor Stages				
Product Family	PLSX with and without PLST(/M) Top Plate 1" Stage	PLSXY with and without PLST(/M) Top Plate 1" Stage	LNR Series 25 mm Stage	LNR Series 50 mm Stage
Click Photo to Enlarge				
Travel	1"		25 mm	50 mm
Maximum Velocity	7.0 mm/s		2.0 mm/s	50 mm/s
Possible Axis				



Configurations	X, XY	X, XY, XYZ	X, XY, XYZ
Mounting Surface Size	3" x 3"	60 mm x 60 mm	100 mm x 100 mm
Additional Details			

Stepper Motor Stages					
Product Family	NRT Series 100 mm Stage	NRT Series 150 mm Stage	LTS Series 150 mm Stage	LTS Series 300 mm Stage	MLJ250 50 mm Vertical Stage
Click Photo to Enlarge					
Travel	100 mm	150 mm	150 mm	300 mm	50 mm
Maximum Velocity	30 mm/s		50 mm/s		3.0 mm/s
Possible Axis Configurations	X, XY, XYZ		X, XY, XYZ		Z
Mounting Surface Size	84 mm x 84 mm		100 mm x 90 mm		148 mm x 131 mm
Additional Details					

DC Servo Motor Stages

Thorlabs offers linear translation stages with removable or integrated DC servo motors. These stages feature low profiles and many can be assembled in multi-axis configurations.





DC Servo Motor Stages				
Product Family	MT Series 12 mm Stages	PT Series 25 mm Stages	MTS Series 25 mm Stage	MTS Series 50 mm Stage
Click Photo to Enlarge				
Travel	12 mm	25 mm	25 mm	50 mm
Maximum Velocity	2.6 mm/s		2.4 mm/s	
Possible Axis Configurations	X, XY, XYZ		X, XY, XYZ	
Mounting Surface Size	61 mm x 61 mm	101.6 mm x 76.2 mm	43 mm x 43 mm	
Additional Details				

DC Servo Motor Stages				
Product Family	M30 Series 30 mm Stage	M30 Series 30 mm Monolithic XY Stage	M150 Series 150 mm XY Stage	KVS30 30 mm Vertical Stage
Click Photo to Enlarge				
Travel	30 mm		150 mm	30 mm
Maximum Velocity	2.4 mm/s		X-Axis: 170 mm/s Y-Axis: 230 mm/s	8.0 mm/s
Possible Axis Configurations	X, Z	XY, XZ	XY	Z
Mounting				

Surface Size	115 mm x 115 mm	272.4 mm x 272.4 mm	116.2 mm x 116.2 mm
Additional Details			

Direct Drive Stages

These low-profile stages feature integrated brushless DC servo motors for high speed translation with zero backlash. When no power is applied, the platforms of these stages have very little inertia and are virtually free running. Hence these stages may not be suitable for applications where the stage's platform needs to remain in a set position when the power is off. We do not recommend mounting these stages vertically.

Direct Drive Stages					
Product Family	DDS Series 50 mm Stage	DDS Series 100 mm Stage	DDS Series 220 mm Stage	DDS Series 300 mm Stage	DDS Series 600 mm Stage
Click Photo to Enlarge					
Travel	50 mm	100 mm	220 mm	300 mm	600 mm
Maximum Velocity	500 mm/s		300 mm/s	400 mm/s	400 mm/s
Possible Axis Configurations	X, XY		X, XY	X	X
Mounting Surface Size	60 mm x 52 mm		88 mm x 88 mm	120 mm x 120 mm	
Additional Details					

[Hide Single-Axis Flexure Stages: 5 mm Travel](#)

Single-Axis Flexure Stages: 5 mm Travel



The stages are supplied with a differential micrometer drive, which provides coarse and fine adjustment. An optional piezo drive is available, with or without strain gauge feedback for closed- and open-loop operation, respectively. The NFL5 series stage is ideal for a variety of applications, including interferometry, microscopy, and other precision nanopositioning applications.

See the *Specs* tab above for more detailed information, including compatible controllers. We offer the NFL5DP20 stage bundled with a controller at a discounted price below. Compatible power supplies are sold separately below.

Part Number	Description	Price	Availability
NFL5D/M	NanoFlex™ 5 mm Travel Translation Stage with Differential Drive, Metric	\$940.84	Today
NFL5DP20/M	NanoFlex™ 5 mm Travel Translation Stage with Diff. Drive and 20 µm Piezo Actuator, Metric	\$1,145.15	Today
NFL5DP20S/M	NanoFlex™ 5 mm Travel Translation Stage with Diff. Drive and Closed-Loop 20 µm Piezo Actuator, Metric	\$1,543.11	Today
NFL5D	NanoFlex™ 5 mm Travel Translation Stage with Differential Drive, Imperial	\$940.84	Today
NFL5DP20	NanoFlex™ 5 mm Travel Translation Stage with Diff. Drive and 20 µm Piezo Actuator, Imperial	\$1,145.15	Today
NFL5DP20S	NanoFlex™ 5 mm Travel Translation Stage with Diff. Drive and Closed-Loop 20 µm Piezo Actuator, Imperial	\$1,543.11	Today

[Hide Open-Loop, Single-Axis Stage & Controller Bundle](#)

Open-Loop, Single-Axis Stage & Controller Bundle



- ▶ NFL5DP20 NanoFlex™ Flexure Stage Bundled with Piezo Driver and Base Plate
- ▶ Includes USB and SMC Cables
- ▶ Power Supply Sold Separately Below
- ▶ 10% Savings Over Individual Components

The KPZNFL5 bundle includes the KPZ101 K-Cube™ Piezo Driver, the ideal driver for the NFL5DP20 stage, as well as the cables necessary for an open-loop piezo positioning system. The KPZNFL5 bundle also includes a NFL5P1 base plate. Compatible power supplies for the KPZ101 are sold separately below.

Please see the *Bundle* tab for more information on this bundle.

Part Number	Description	Price	Availability
KPZNFL5	NanoFlex™ 5 mm Travel Stage & KPZ101 Piezo Driver, Imperial	\$1,689.22	Lead Time

[Hide NFL5 Series Mounting Adapters](#)

NFL5 Series Mounting Adapters



The NFL5P1 and NFL5P2 are adapter plates designed for the NFL5 Series of translation stages. The NFL5P1 is a universal base plate with slots on the side that enable obstruction-free mounting onto an optical breadboard. This base is ideal for XY or XYZ multi-axis configurations where the standard counterbores in the middle of the stages are obstructed.

The NFL5P2 is an angle bracket that allows a NFL5 Series stage to be mounted vertically in 2-axis and 3-axis configurations.

Part Number	Description	Price	Availability
NFL5P1/M	NanoFlex™ NFL5D Series Base Plate, Metric Taps	\$55.83	Today
NFL5P2/M	NanoFlex™ NFL5D Series Angle Bracket, Metric Taps	\$115.23	7-10 Days
NFL5P1	NanoFlex™ NFL5D Series Base Plate	\$55.83	Today
NFL5P2	NanoFlex™ NFL5D Series Angle Bracket	\$115.23	Today

[Hide Compatible Power Supplies](#)

Compatible Power Supplies



- ▶ Individual ± 15 V/5 V Power Supply
 - ▶ TPS002: For up to Two K-Cubes™ or T-Cubes™ with Mini-DIN Input*
- ▶ USB Controller Hubs Provide Power and Communications
 - ▶ KCH301: For up to Three K-Cubes or T-Cubes
 - ▶ KCH601: For up to Six K-Cubes or T-Cubes

The TPS002 supplies power for up to two K-Cubes* or T-Cubes. The cubes still require individual computer connection via USB cable.

The KCH301 and KCH601 USB Controller Hubs each consist of two parts: the hub, which can support up to three (KCH301) or six (KCH601) K-Cubes or T-Cubes, and a power supply that plugs into a standard wall outlet. The hub draws a maximum current of 10 A; please verify that the cubes being used do not require a total current of more than 10 A. In addition, the hub provides USB connectivity to any docked K-Cube or T-Cube through a single USB connection.

For more information on the USB Controller Hubs, see the full web presentation.

*The TPS002 can only support one KNA-VIS or KNA-IR controller or one KLD101 driver and should not be used to power any additional units as that may exceed current limitations.

Part Number	Description	Price	Availability
TPS002	± 15 V/5 V Power Supply Unit with Mini-DIN Connectors for up to Two K- or T-Cubes	\$128.29	Today
KCH301	USB Controller Hub and Power Supply for Three K-Cubes or T-Cubes	\$598.63	Today
KCH601	USB Controller Hub and Power Supply for Six K-Cubes or T-Cubes	\$724.52	Today